



MDVN 53 P

PORTABLE COMPRESSOR

SUPER SILENT | POWERFUL & COMPACT



WEIGHT (with brakes)	970 Kg	2138 lbs
WEIGHT (without brakes)	870 Kg	1918 lbs

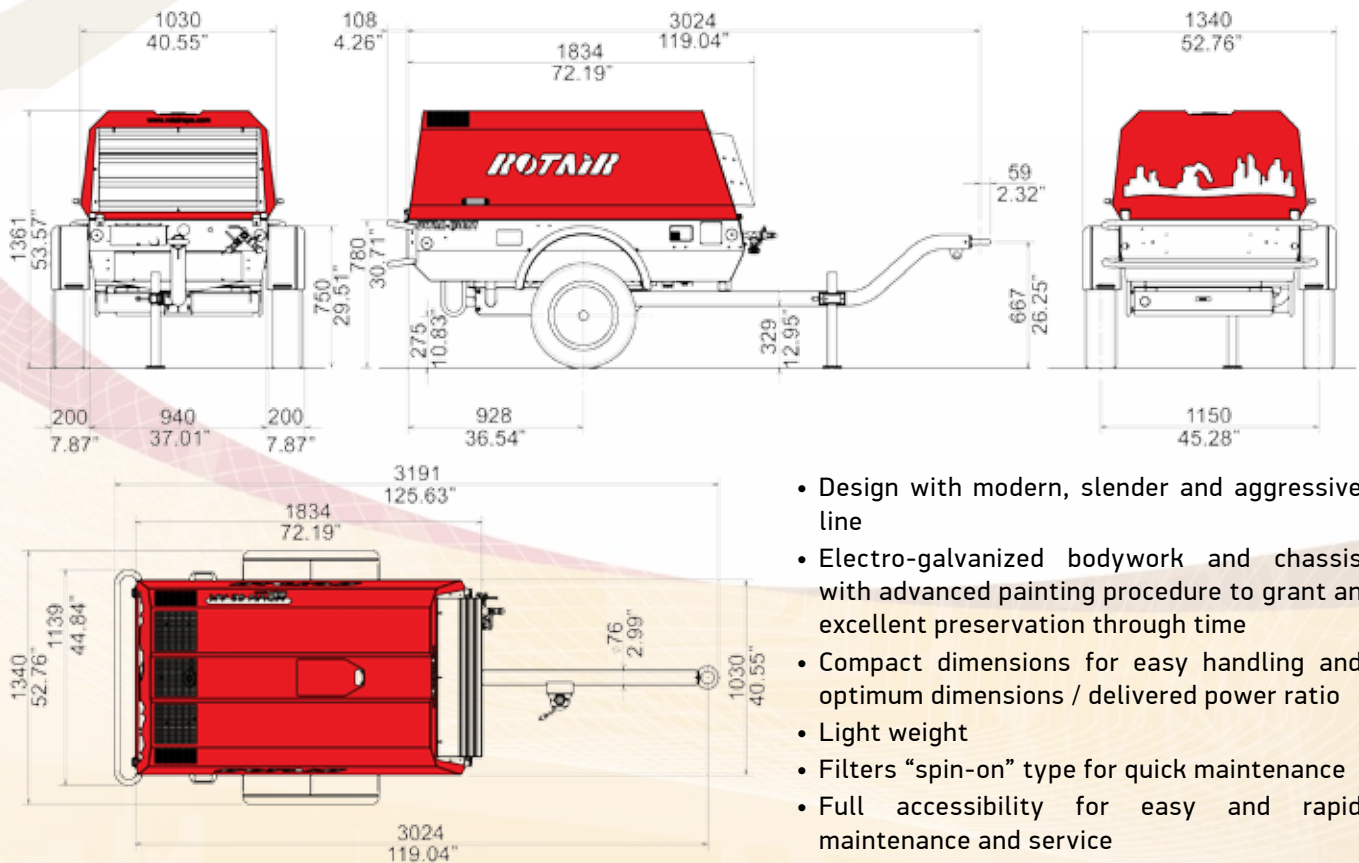

- Design with modern, slender and aggressive line
- Electro-galvanized bodywork and chassis with advanced painting procedure to grant an excellent preservation through time
- Compact dimensions for easy handling and optimum dimensions / delivered power ratio
- Light weight
- Filters "spin-on" type for quick maintenance
- Full accessibility for easy and rapid maintenance and service

OPTIONS AND ACCESSORIES:

- Drawbar with or without brakes, caravan-type ball connection - Skid version
- Clog indicator for engine air filter - Fuel indicator
- Sandblasting kit (cooler for compressed air cooling and dew separator)
- Line oiler for pneumatic tools - Warming for compressed air

MDVN 53 P TECHNICAL DATA



- Exclusive pneumatic control system, developed by ROTAIR, to adjust automatically engine revs, depending on the air to be delivered. This system is highly reliable and ensures fuel consumption saving
- Start/stop "INTELLIGENT SYSTEM", exclusive from ROTAIR, to prevent the risk of incorrect procedures during specific functioning
- Air/oil separator filter, highly oversized, can guarantee an excellent air/oil separation
- The air and oil filters of the compressor and the air and oil filters of the engine are independent
- Single stage oversized air filter for compressor part, to guarantee good filtering of the air intake by airend. As option, Two-stage air filter
- Two-stage air filter for engine part
- Combined radiator allowing both compressor oil cooling and engine liquid cooling



THE RESPECT OF ORDINARY MAINTENANCE INTERVALS AND THE USE OF GENUINE SPARE PARTS ENSURE CONSTANT AND OPTIMAL PERFORMANCES AND A RELIABLE DURABILITY THROUGH TIME.

COMPRESSOR

Operating pressure	7 bar – 102 psi
<i>Possibility to have different operating pressures up to 14/15 bar and dual pressure*</i>	
Free air delivery	5200 lt/min – 185 CFM
Minimum working pressure	5 bar – 73 psi
Drive system engine-airend	Direct Drive
Compressor cooling system	Air/Oil
Oil cooling capacity	9 lt
Air outlet temperature	40°C – 105°F + Ambient temperature
Outlet valves	3 x 3/4"
Noise level EECno 2000/14	< 98 LWA
Battery capacity	12Vcc- 400A-70Ah (EN)
Fuel tank capacity	50 lt
Consumes	7,3 lt/ hour (6,9 working hours)

DIESEL ENGINE

Engine make	PERKINS
Engine type	404-D-22
Engine system	4 stokes - Inline - Indirect Injection
Displacement	2216 cc
N. cylinders	4
Aspiration	Natural
Max engine power@2900 RPM	37,0 kW – 50,0 HP
Max engine speed	2900 RPM
Min engine speed	1700 RPM
Cooling system	Water
Cooling system capacity	8 lt
Lubrication system	Oil
Lubrication system capacity	9 lt

ENVIRONMENTAL CONDITIONS	(Standard version*)
Max ambient temperature	50°C – 122°F
Max altitude	1800 mt a.s.l.
Min working temperature	-10°C – 14°F

* For versions with different operating pressures or for requests of machines to be used under particular ambient temperature conditions, data have to be previously asked to our technical dept.

* All images and pictures are indicative. Data can be changed without prior notice.

A NEW WORKING CONCEPT!

PORTABLE COMPRESSOR
SUPER SILENT
POWERFUL & COMPACT

ROTAIR®

TECHNOLOGY AND ENGINEERING SOLUTIONS

Via Bernezzo, 67 - 12023 Caraglio (Cn) ITALY

Tel: +39 0171.619676 / Fax: +39 0171.619677

www.rotairspa.com • info@rotairspa.com